

The WPS89 series is corrosion resistant small wall pack designed to meet the rugged demands of industrial and commercial applications. The housing can be mounted directly over a standard 4" outlet box or surface wired through ½" conduit entries. Suitable for wet locations, these lights provide illumination for safety and security along building perimeters. Available in both wired and non wired versions

Product Specifications

Housing:

Durable die cast aluminum with three ½" threaded conduit entries for surface wiring or photocell installation. A continuous one piece gasket ensures a weather tight seal.

Lens:

Clear Prismatic Borosilicate glass refractor

Reflector:

One piece anodized aluminum reflector for maximum lumen output

Socket:

Medium Base E26 – HID units
Universal four-pin – Compact fluorescent

Lamps:

Metal Halide 100W Max, High Pressure Sodium 150W Max or PLT42W-1 compact fluorescent (all lamps are included)

Ballast:

Single-tap – 120 Volts
Multi-tap – 120, 208, 240, 277 Volts
Universal – 120 -277 Volts



Applications

- * Parking areas
- * Entrances
- * Walkways
- * Underpasses
- * Loading docks
- * Recreation areas

Finish:

Dark bronze (BZ) powder paint finish is standard

Approvals:



UNDERWRITERS
LABORATORIES



Contact our engineering staff if you require further application information.

Part Number Listing

Part No.	Series Number	Lamps	Ballast
R800006	WPS89-HPS100-120-BZ	HPS100W	120V/60HZ
R800007	WPS89-HPS150-120-BZ	HPS150W	120V/60HZ
R800126	WPS89-MH100-MT-BZ	MH100W	MT/60HZ
R800127	WPS89-MH70-MT-BZ	MH70W	MT/60HZ
R800010	WPS89-PLT421-UNV-BZ	PLT42W*1	120~277V 60HZ
R800115	WPS89-BZ	N/A	N/A

* Additional lamp wattages and ballast voltages are available. Contact factory for details.

Pulse Start units meet or exceed the minimum efficiency requirements of the Energy Independence and Security Act of 2007 (EISA)

** Other finishes are available. Please contact the factory for details.

So that we may continue to supply the best possible product, specifications may change without notice. Consult the Paraflex website for the most up-to-date product information.

Dimensions

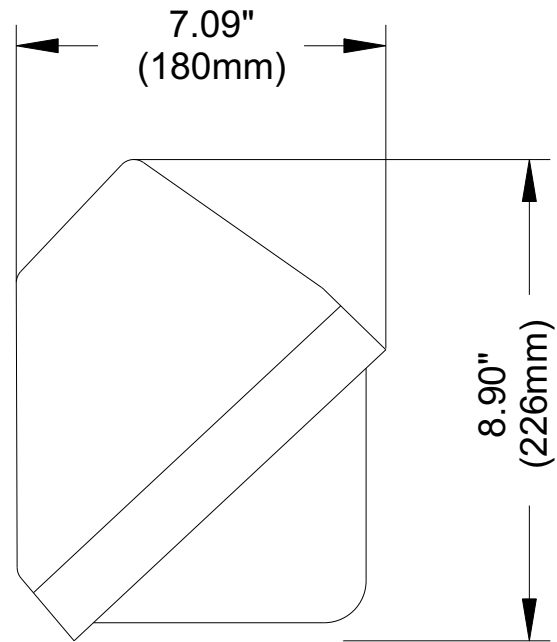
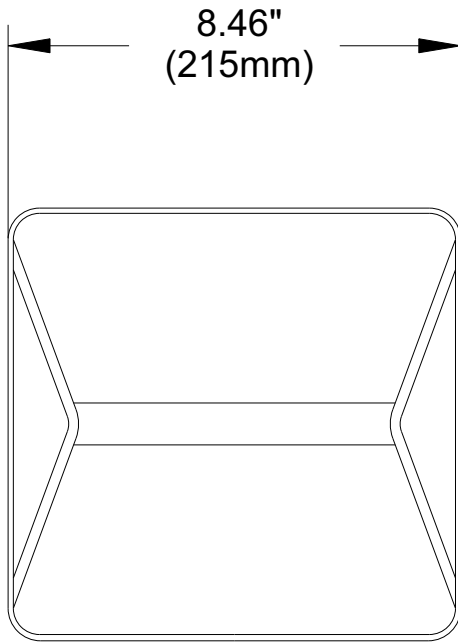

WPS89