



CV300 Series 12" x 12"

VANDAL
RESISTANT

FIXTURE FEATURES

- **Housing** - Die Formed heavy gauge steel with White powder coat finish. Neoprene gasket eliminates moisture, dust & insects. Optional bronze conduit adapter available for incandescent and fluorescent versions. Die Cast Aluminum Back Box for HID versions.
- **Diffuser** - Injection molded prismatic polycarbonate with UV inhibitors. Standard clear with white prismatic as option. Drill points for maximum security. Integral (molded) locking lugs opposite the retention screws.
- **Light Source** - Versions available for incandescent 2X75W (CV301 series), Fluorescent 7W-9W-13W (CV302 series) & HID 50W-175W MH/HPS (CV303 series).
- **Hardware** - Standard stainless steel screws or optional tamper proof tork screws.
- **Mounting** - Wall or ceiling mounting for indoor or outdoor locations.
- **Regulatory** - UL & CUL listed for wet locations with ceiling mount and damp locations for wall mounting.
- **Applications** - Security, public, or high abuse area. Correctional facilities.

Part Number	Description
R650333	CV301CU Kit—Incandescent style, clear diffuser, socket included
R650353	CV302CU Kit—Fluorescent style, clear diffuser, no socket
R650394	CV303CU HID unit, clear diffuser, socket bracket, socket
R650298	CV300PC Clear polycarbonate prismatic diffuser
R650313	CV300SH Heavy gauge steel housing
R650304	CV300SA Kit—SH adapter, 1/2" Conduit—Bronze

PARAFLEX INDUSTRIES

The Manufacturers Source For
Lighting Parts And Products

CV300 Series VANDAL RESISTANT

CV303

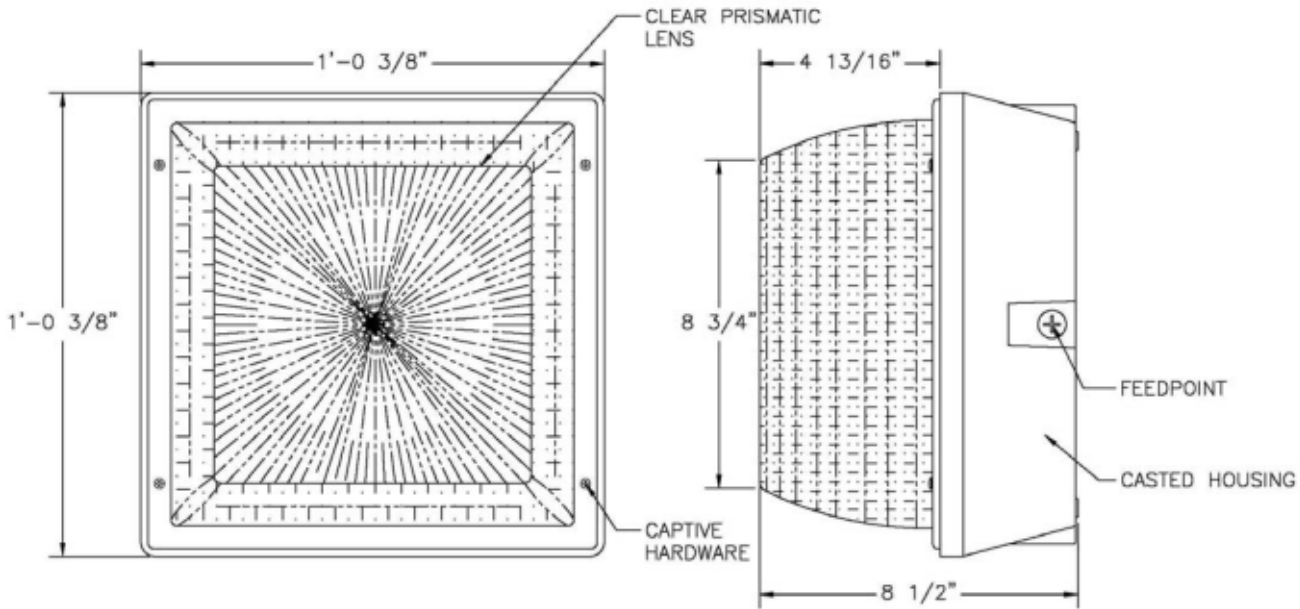

**VANDAL
RESISTANT**

