



CV200 Series 8" x 8"

**VANDAL
RESISTANT**

FIXTURE FEATURES

- **Housing** - Die Formed heavy gauge steel with White powder coat finish. Neoprene gasket eliminates moisture, dust & insects. Optional bronze conduit adapter available for incandescent and fluorescent versions. Die Cast Back Box for HID versions.
- **Diffuser** - Injection molded prismatic polycarbonate with UV inhibitors. Standard clear with white prismatic as option. Drill points for maximum security. Integral (molded) locking lugs opposite the retention screws.
- **Light Source** - Versions available for incandescent 1X75W (CV201 series), Fluorescent 7W-9W-13W (CV202 series) & HID 35W-70W MH/HPS (CV203 series).
- **Hardware** - Standard stainless steel screws or optional tamper proof tork screws.
- **Mounting** - Wall or ceiling mounting for indoor or outdoor locations.
- **Regulatory** - UL & CUL listed for wet locations with ceiling mount and damp locations for wall mounting.
- **Applications** - Security, public, or high abuse area. Correctional facilities.

Part Number	Description
R650183	CV201CU Kit—Incandescent style, clear diffuser, socket included
R650208	CV202CU Kit—Fluorescent style, clear diffuser, no socket
R650244	CV203CU HID style, clear diffuser, socket bracket, socket
R650148	CV200PC Clear prismatic Lexan diffuser
R650143	CV200PCW White polycarbonate prismatic diffuser
R650163	CV200SH Heavy gauge steel housing—White
R650154	CV200SA Conduit adapter pan, with screws & nuts—Bronze

PARAFLEX INDUSTRIES

The Manufacturers Source For
Lighting Parts And Products

CV200 Series

R650148

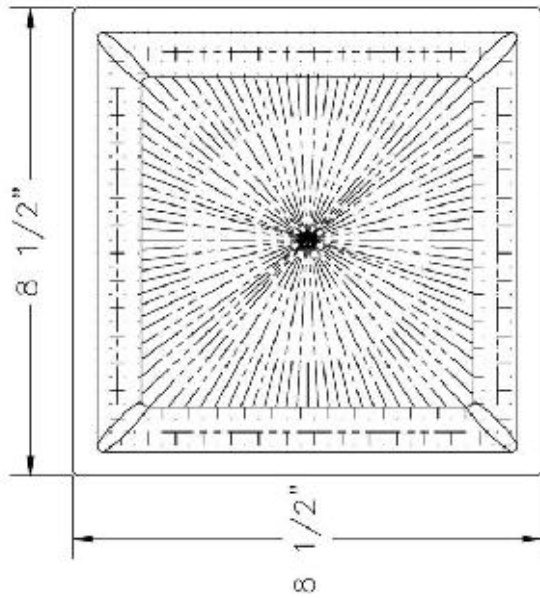
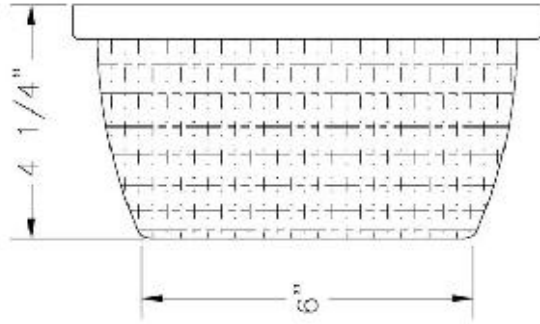

CV203

CLEAR PRISMATIC LENS

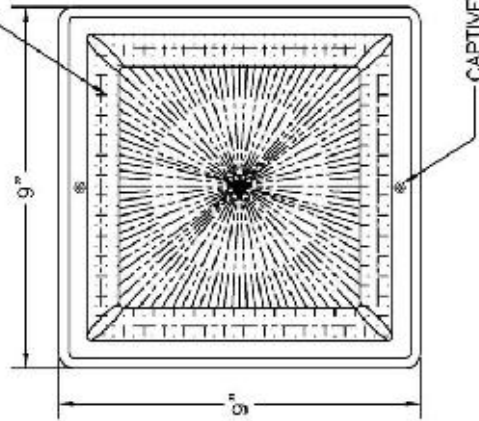
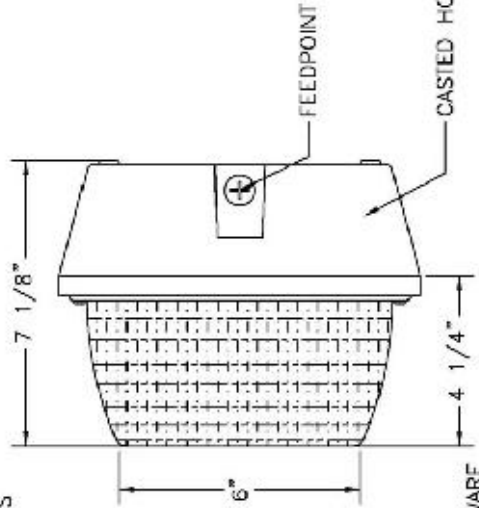

R650163

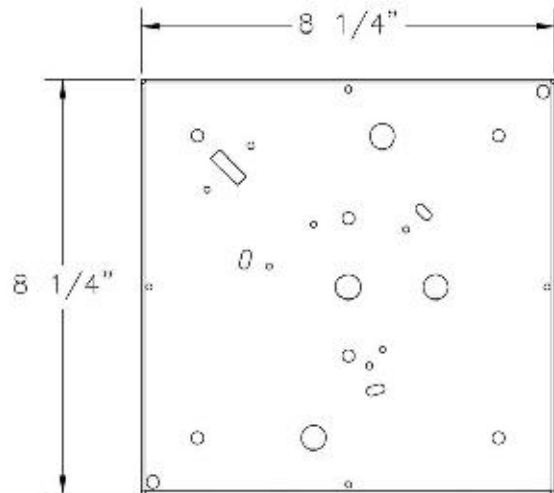
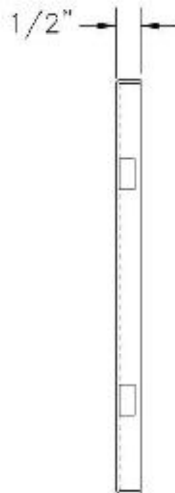

VANDAL RESISTANT